

SHURE®

Shure Brothers Incorporated
222 Hartrey Avenue
Evanston IL 60202-3696 U.S.A.

Model 200M PROLOGUE User Guide

PROLOGUE MICROPHONE MIXER



The Shure Model 200M PROLOGUE Microphone Mixer is a compact, portable, four-channel unit designed for quality sound mixing and reproduction in paging and sound reinforcement applications where economy is an important consideration. When used with Shure PROLOGUE microphones and the Shure Model 210A PROLOGUE Power Amplifier, the 200M provides optimum sound at extremely low cost.

Features

- Four low-impedance XLR (3-pin professional) microphone inputs, one switchable to auxiliary (aux) level
- High-level phono-type aux input suitable for tape, tuner and accessories
- Individual volume controls allow adjustment of each channel level
- Master volume control adjusts overall output level
- Balanced low-impedance microphone-level and unbalanced aux-level outputs match most power amplifier inputs
- Compact, modular design, suitable for stacking on top of Shure 210A Power Amplifier
- Rugged and reliable for years of trouble-free operation
- Capability for connecting mixers in tandem, providing additional microphone inputs
- Powered by 120-volt ac adapter (Model PS20, listed by Underwriters Laboratories, Inc., and listed by Canadian Standards Association as Certified), or 220-volt power supply (Model PS20E)

SPECIFICATIONS

Gain (at 1,000 Hz, ± 3 dB)

INPUTS	OUTPUTS	
	Lo Z Mic	Aux
Balanced Lo Z Mic	+31 dB	+71 dB
Aux	-20 dB	+20 dB

Frequency Response (ref 1,000 Hz)

100 Hz to 10,000 Hz, ± 2 dB

Output Hum and Noise (150-ohm source, measured at Aux Out)

Noise (300 Hz to 20 kHz)

-95 dBV (all controls counterclockwise); -72 dBV (channel volume counterclockwise; master

clockwise); -45 dBV (driven channel and master clockwise)

Hum and Noise (20 Hz to 20 kHz)

-90 dBV (all controls counterclockwise); -66 dBV (channel volume counterclockwise; master clockwise); -41 dBV (driven channel and master clockwise)

Input Hum and Noise (150-ohm source)

Equivalent Input Noise

Less than -116 dBV (Lo Z Mic Input to Aux Output)

Equivalent Input Hum and Noise

Less than -112 dBV (Lo Z Mic Input to Aux Output)

Impedance (1 kHz, $\pm 20\%$)

INPUT	FOR USE WITH	ACTUAL
Balanced Lo Z Mic	Balanced or unbalanced 19- to 600-ohm microphones	2 kilohms balanced; 21 kilohms unbalanced (pin 2 "hot"); 1 kilohm unbalanced (pin 3 "hot")
Aux	100-ohm to 10-kilohm unbalanced high-level sources	47 kilohms

OUTPUT	FOR USE WITH	ACTUAL
Lo Z Mic	Balanced or unbalanced 19- to 600-ohm microphone-level input circuits	150 ohms
Aux	Unbalanced high-impedance (10 kilohms or more) auxiliary input circuits	2 kilohms

Clipping Levels (minimum)

Input

Balanced Lo Z Mic -22 dBV

Aux -1 dBV

Output

Lo Z Mic -20 dBV

Aux +9 dBV

Distortion (1 kHz)

Less than 1.0% total harmonic distortion at either input when low-impedance microphone output is at -34 dBV level and auxiliary level output is at +6 dBV level (driven channel and master clockwise)

Phase

All microphone inputs and outputs in phase. Aux input and output in phase with each other, and in phase with pin 2 of microphone connectors

Temperature Range

Operating: -18° to $+57^{\circ}$ C (0° to $+135^{\circ}$ F)
Storage: -29° to $+74^{\circ}$ C (-20° to $+165^{\circ}$ F)

Power

12 to 18 Vdc, 50 mA min.

Input: Model PS20 Ac Adapter: $120 \pm 10\%$ Vac, 60 Hz, 9 W; Model PS20E Power Supply: $220 \pm 10\%$ Vac, 50 Hz, 5 W

Output: Model PS20: 12 Vdc at 400 mA; Model PS20E: 12 Vdc at 250 mA

Overall Dimensions

69.9 mm H x 241 mm W x 143 mm D (2-3/4 x 9-1/2 x 5-5/8 in.)

Net Weight

1.25 kilograms (2 lb 12 oz)

INSTALLATION

Connections between Units

For balanced-line connections (isolated from ground), use two-conductor, shielded, low-capacity cable. For unbalanced (high-impedance) connections, use single-conductor, shielded, low-capacity cable.

Inputs

A maximum of four low-impedance dynamic, ribbon or condenser* microphones can be connected to the Mic 1, 2, 3 and 4 connectors. The inputs will accept microphones with impedance ratings of 19 to 600 ohms. The 200M will not function with crystal or ceramic microphones.

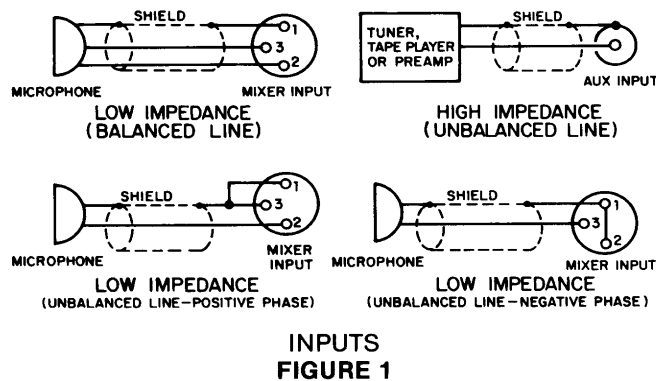

The microphone input connectors are professional female XLR types (see Figure 1). Balanced low-impedance microphones can be connected with standard microphone cables. For unbalanced microphones, the signal ("hot") conductor is connected to pin 2 and the shield to pins 1 and 3. If required, the signal conductor can be connected to pin 3 and the shield to pins 1 and 2; however, the polarity will be reversed and the input impedance reduced. If high-impedance microphones (with either XLR or phone plug connectors) are to be used with the 200M, a line matching transformer (Shure A95 series or equivalent) must be inserted between the microphone and 200M microphone input.

Note that some condenser microphones produce a very high output signal that can overload the mixer input. A Shure Model A15AS Microphone Attenuator inserted between the microphone and mixer input will eliminate this problem.

When the rear-panel Aux In/Mic 4 switch is in the Aux In position, the phono pin jack marked Aux In can be

used with a high-level, high-impedance source such as a tape or CD player, am-fm tuner, or phono cartridge preamplifier. Note that the Mic 4 connector is not operative when the switch is in the Aux In position.

*Battery or externally powered.

Outputs

The male XLR connector marked Lo Z Mic Out is the mixed output of all the input sources. It can be connected to a 19-to 600-ohm microphone line to feed a power amplifier for sound reinforcement or paging applications, or a low-impedance tape recorder input (see Figure 2).

The phono jack marked Aux Out is a high-impedance, high-level output designed primarily to feed a power amplifier requiring a 0.5- to 2.0- volt input, or the auxiliary or tuner input of an amplifier or tape recorder.

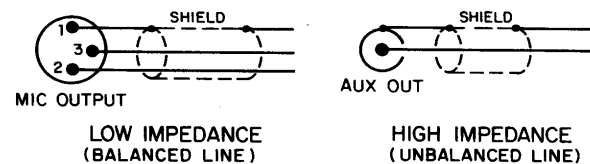

OPERATION

Power Connections

Connect the output plug of a Shure PS20 Ac Adapter or PS20E Power Supply to the 12 Vdc power input of the 200M. Connect the PS20 to a $120 \pm 10\%$ Vac, 60 Hz power source, or connect the PS20E to a $220 \pm 10\%$ Vac, 50 Hz power source. Turn on the Power switch. The LED above the Power switch will light when power is applied.

Volume Controls

The Master and individual microphone gain controls for each channel are identified on the front panel. The individual gain controls should generally be set between 5 and 10, and the Master gain control adjusted to the required output. Unused individual channel gain controls should be kept at minimum gain (full counterclockwise).

CONNECTING TWO UNITS

Two 200M mixers can be connected in tandem to give a total of seven microphone channels, or six microphone channels plus an auxiliary input. To combine two mixers, proceed as follows (see Figure 3).

1. Connect the Aux Out of Unit 1 to the Aux In of Unit 2.
2. Connect all microphones and set the microphone gain controls to 0.
3. Set the Aux In/Mic 4 switch on Unit 2 to Aux In.
4. Connect the output signal of Unit 2 (from either the Aux Out or Lo Z Mic Out connector) to the input of the following equipment (amplifier, tape recorder, etc.).
5. Set the Unit 1 Master control to 3 and the Unit 2 Mic 4/Aux control to 3.
6. The Unit 2 Master control is now the master control for both units.

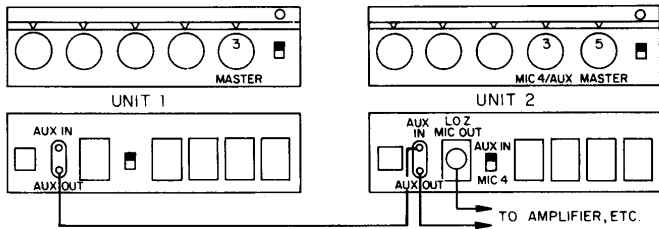

CONNECTING TWO UNITS
FIGURE 3

7. Advance the Unit 2 Master control to about 5 and adjust the individual microphone controls for proper

levels. If the overall gain is too high or too low, the Unit 2 Master control can be adjusted.

8. If an auxiliary-level input, such as a tape recorder or tuner, is needed, use the Aux In connector on Unit 1. Set the Unit 1 Aux In/Mic 4 switch to Aux In, and use the Mic 4/Aux control to set the Aux In gain. Note that the Unit 1 Mic 4 input is not operative when the Aux In input is in use (six microphone inputs plus one auxiliary input).

OPTIONAL ACCESSORIES

- Microphone Attenuator A15AS
Line Matching Transformer A95 Series

REPLACEMENT PARTS LIST

REFERENCE DESIGNATION	DESCRIPTION	SHURE PART NO. AND/OR COMMERCIAL ALTERNATE	REFERENCE DESIGNATION	DESCRIPTION	SHURE PART NO. AND/OR COMMERCIAL ALTERNATE
A1	Ac Adapter, 120 Vac, 60 Hz, 9W	Shure PS20	J501	Connector, Dual Phono (Aux In, Out)	Shure 10203FH
A1	Power Supply, 220 Vac, 50/60 Hz, 5W	Shure PS20E	J601	Connector, Dc power (12 Vdc)	Shure 10204FH
C101-C108	Capacitor, Electrolytic, 10 μ F, 25V	Shure 10102FH; Sprague 513D106M050JA4	L601-L602	Ferrite Bead Ring, 1.3 μ F, 3.5 mm \varnothing	Shure 10205FH; Stackpole 57-3425
C117-C120, C122-C123, C125, C201	Capacitor, Electrolytic, 4.7 μ F, 50V	Shure 10105FH; Sprague 513D475M063JA4	MP1-MP5	Knob, Control (Mic 1-Mic 4, Master)	Shure 10206FH
C127	Capacitor, Electrolytic, 47 μ F, 16V	Shure 10107FH; Mallory VTL-47S16	P1	Connector, XLR (Mic Out)	Shure 10207FH
C128	Capacitor, Electrolytic, 2200 μ F, 25V	Shure 10108FH; Mallory VTL-2200S25	R101-R108	Resistor, Metal Oxide Film, 36k, 1/4W, 1%	Shure 10301FH; TRW/IRC TO-60
D101	Diode, Silicon, 100V, 1/2A	Shure 86A404; Motorola 1N4002	R204-R207	Potentiometer, Linear Taper, 20k (Mic 1-Mic 4)	Shure 10313FH
D401	Light-Emitting Diode, Green	Shure 10201FH; GI MV64531	R208	Potentiometer, Linear Taper, 200k (Master)	Shure 10314FH
J301-J304	Connector, XLR (Mic Input)	Shure 10202FH	R309-R316	Resistor, Metal Oxide Film, 1k, 1/4W, 1%	Shure 10316FH; TRW/IRC TO-60
			S1, S401	Switch, Slide, DPDT	Shure 10401FH
			T101	Transformer, Output	Shure 10501FH
			U101-U103	Integrated Circuit, Dual Op Amp	Shure 86A811A; Motorola MC4558

**PRINTED CIRCUIT BOARD
Component Side**

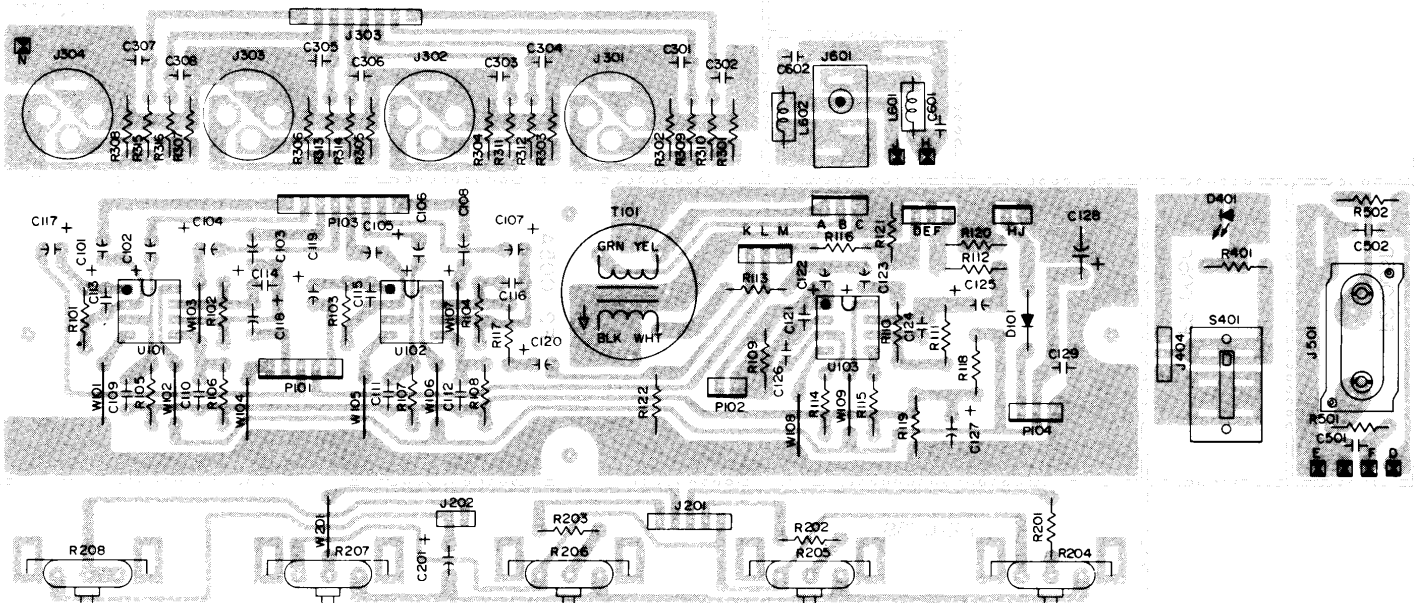

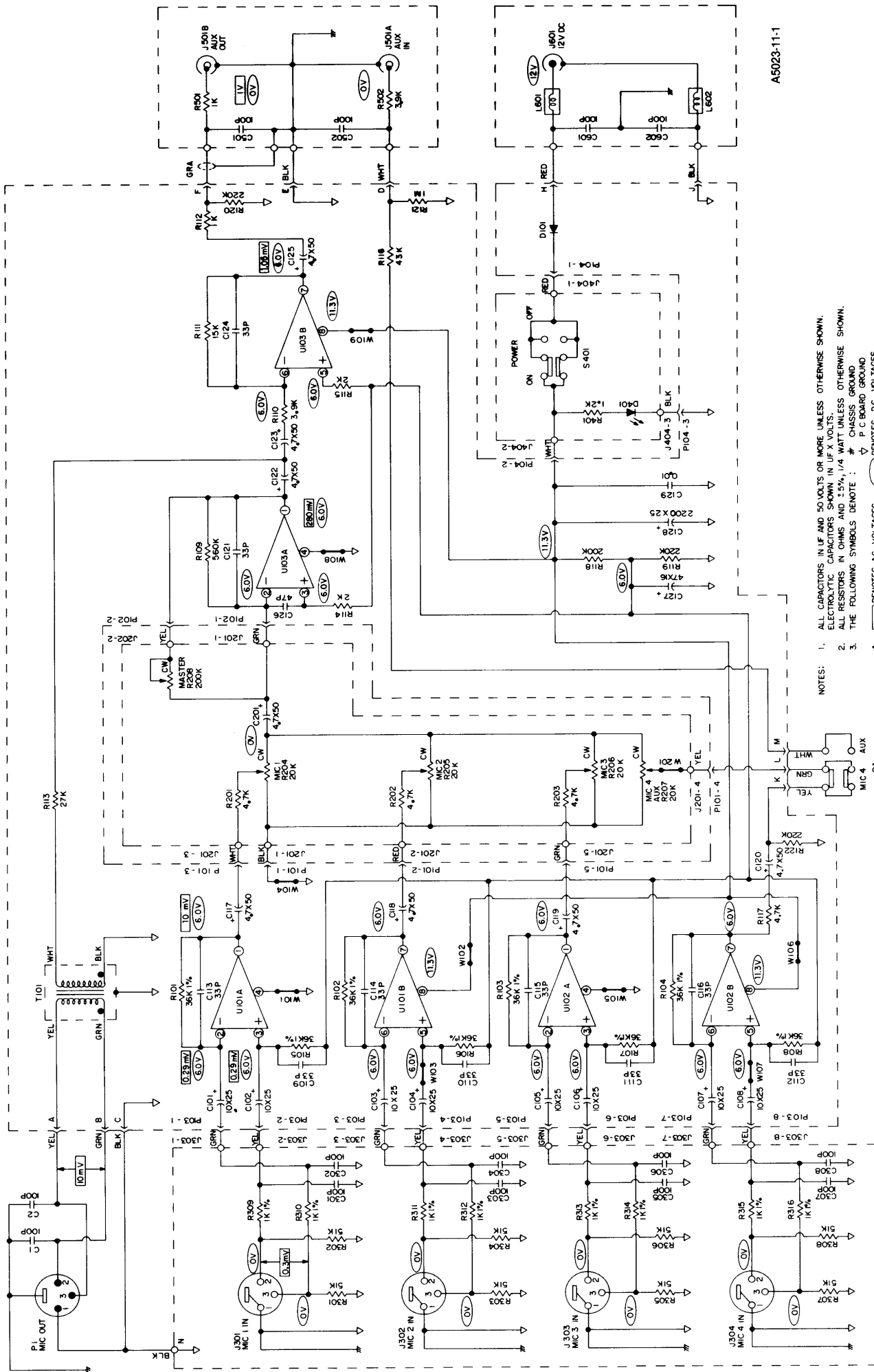

A5023-11-1

- NOTES:
1. ALL CAPACITORS IN μ F AND 50 VOLTS OR MORE UNLESS OTHERWISE SHOWN. ELECTROLYTIC CAPACITORS SHOWN IN μ F X VOLTS.
 2. ALL RESISTORS IN OHMS AND 1%, 1/4 WATT UNLESS OTHERWISE SHOWN.
 3. THE FOLLOWING SYMBOLS DENOTE: # CHASSIS GROUND; ∇ P.C. BOARD GROUND.
 4. \square DENOTES AC VOLTAGES; \circ DENOTES DC VOLTAGES. ALL VOLTAGES MEASURED WITH RES20 (100 OHMS) UNLESS OTHERWISE SHOWN. ALL OTHERS WITH 150 OHMS. MIC. 1 INPUT 1 KHZ THROUGH 150 OHMS SUCH THAT AUX OUTPUT IS 1 VOLT. AUX OUTPUT LOADED WITH 47K OHMS AND MIC OUTPUT LOADED WITH 150 OHMS. DC VOLTAGES MEASURED WITH 1 MEGOHM V.T.V.M. AC VOLTAGES MEASURED WITH 1 MEGOHM. AC V.T.V.M. VOLTAGES ARE TYPICAL AND MAY VARY $\pm 1\%$.
 5. ALL COMPONENTS AND CONNECTIONS ENCLOSED BY DASHED LINES ARE PARTS OF P.C. BOARD ASSEMBLIES.

CIRCUIT DIAGRAM